

ENG

T&R Biofab

3DXPrinter

3D BIO-PRINTING SYSTEM
FOR THE FABRICATION OF ARTIFICIAL TISSUES AND ORGANS

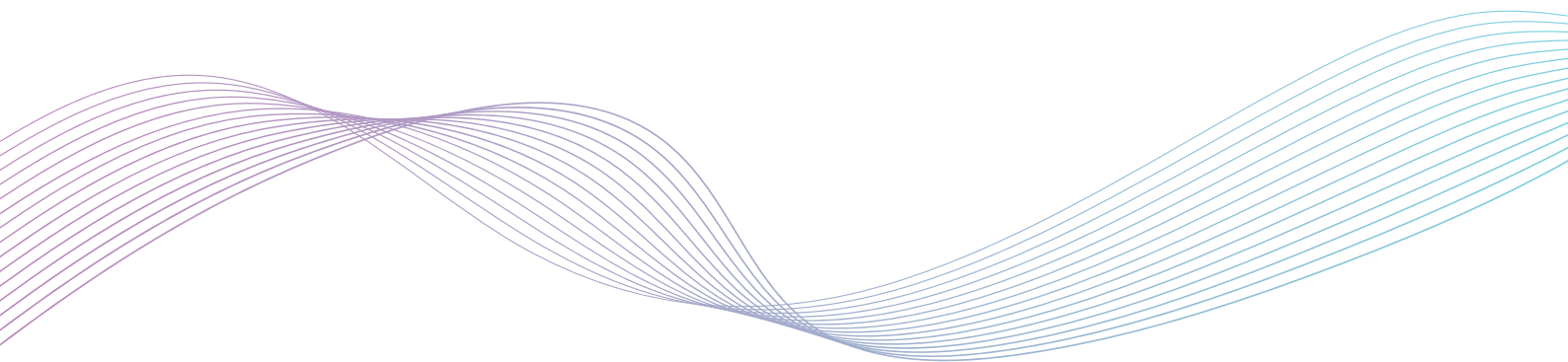

T&R Biofab

T&R Biofab has harnessed the power of 3D printing technology to revolutionize the regeneration of living tissues.

Our relentless pursuit of innovation has led us to develop and commercialize a range of advanced regenerative medicine technologies. These include ECM-based biosurgical solutions, 3D bioprinted organoids, and cell therapy utilizing induced pluripotent stem cells.

Central to our success is the development of our core technologies, encompassing biomaterials, cells, and related processes.

Our dedication to pioneering cutting-edge research and innovation fuels our pursuit of becoming a global leader in regenerative medicine, firmly rooted in our technological competitiveness.

Our aspirations extend far beyond technological leadership. T&R Biofab is driven by a profound mission to contribute to the health and welfare of humanity, alleviating the burdens of life and healing those in pain. We invite you to join us as we shape a future where we can make a lasting impact on the world we live in.

Thank you for your steadfast partnership.

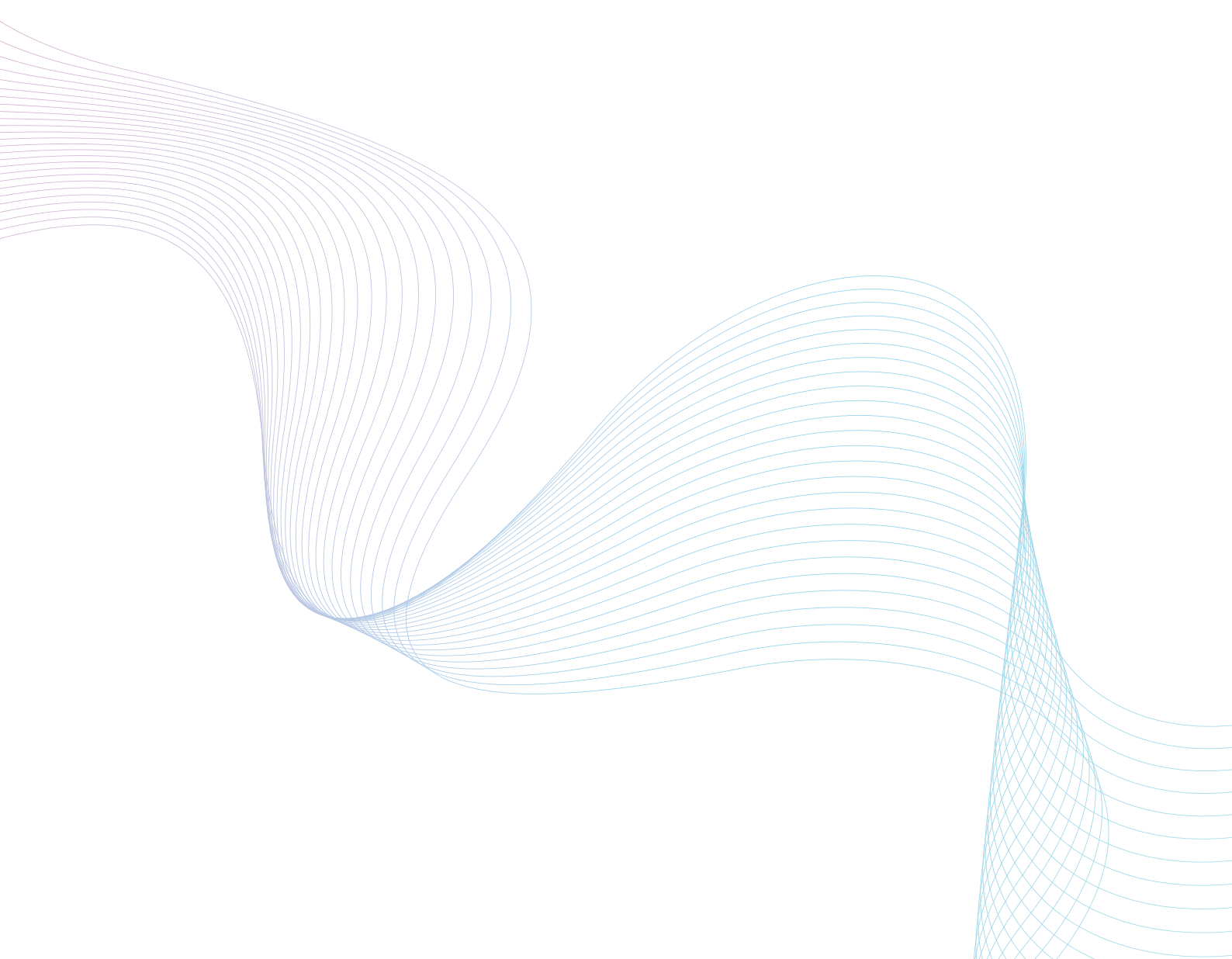

Customizable 3D Printing System

Bespoke hardware and software solutions

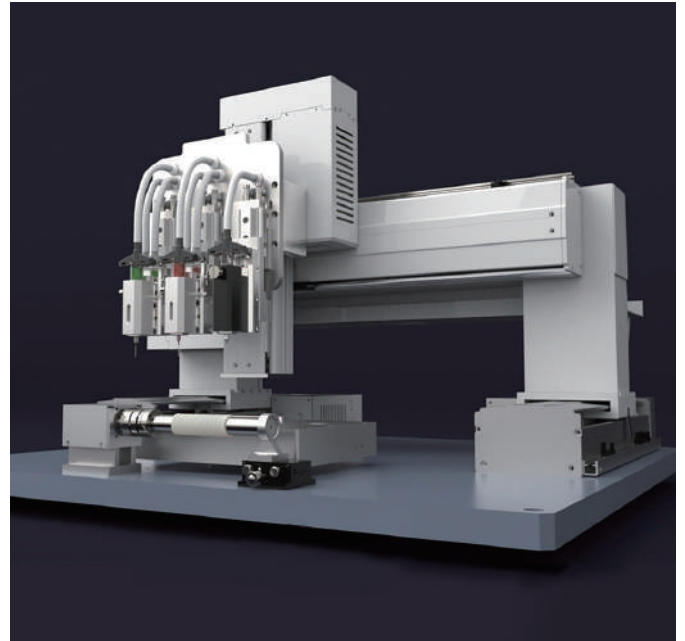

Customizable hardware

- Customization according to research specifications (material, dispense method, etc.)
- Can install up to 6 printing heads (polymer, hydrogel) select among 3 types of base and housings, all available for customization.

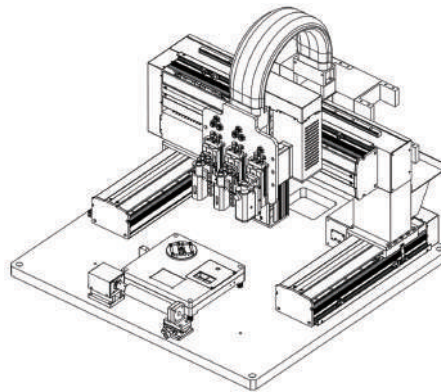
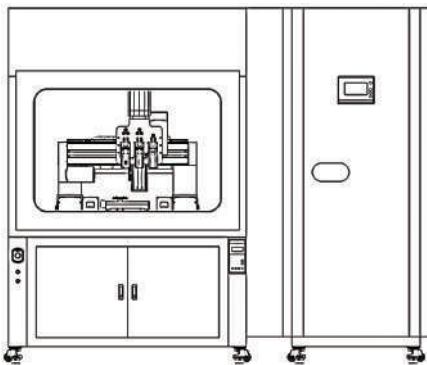

Dedicated software

- G-code assembly function / path modification function.
- Implementation of various geometries with self-created slicers.

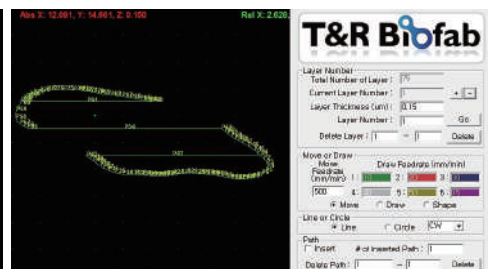
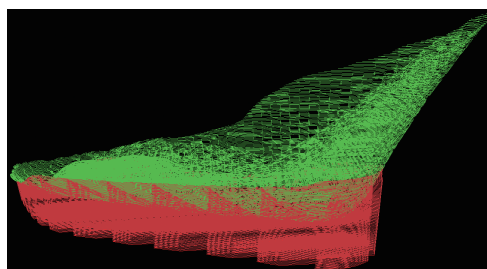
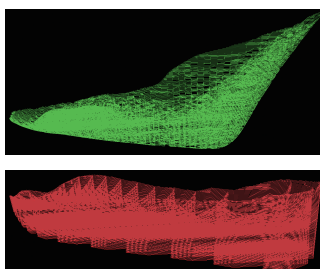

Head options

- Up to 6 polymer and hydrogel heads are available in your choice of configuration, with optional 3ml, 10ml, 30ml syringes.
- Polymer head can be heated from room temperature up to 200 °C, hydrogel head can be cooled and heated from 4 to 60 °C.

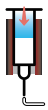
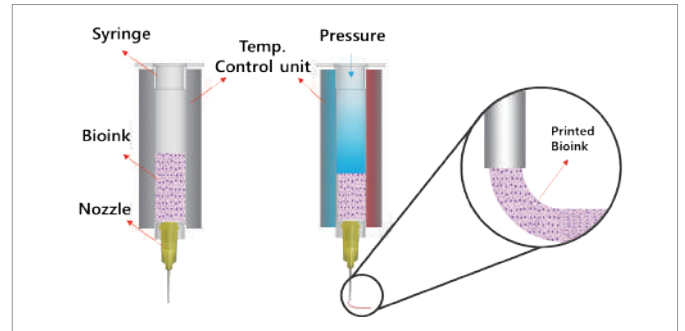
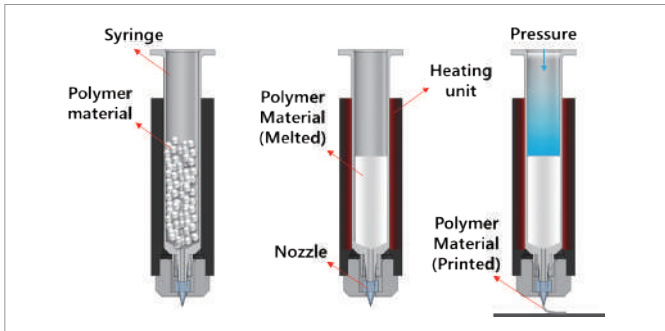

Polymer head (room temperature ~ 200 °C)

The heater allows for fast and precise temperature control up to 200 °C, and pneumatically dispenses polymer materials.



Hydrogel head (4 – 60 °C)

The peltier system allows for fast and precise temperature control from 4 to 60 °C and dispenses hydrogel material using pneumatics.

Base options

- Three types of base specifications available: flat printing, rotational (horizontal), and rotational (vertical printing).
- Select the shape (flat model cylinder model) that suits your needs.
- Flat model base can be cooled and heated from 4 to 60°C.

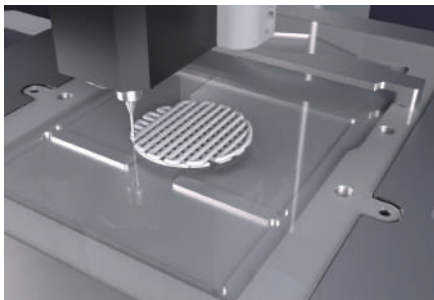

Flat printing

A printing method that ejects material on a flat surfaces such as a flat plate, slide glass, or petri dish.

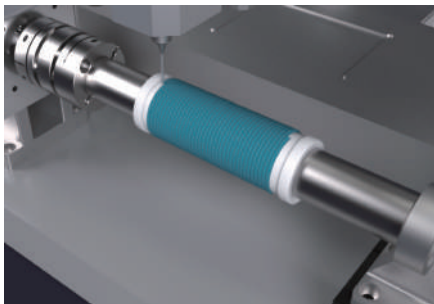

Rotational printing (horizontal)

A printing method that rotates a rod supported on both sides and discharges material onto it.

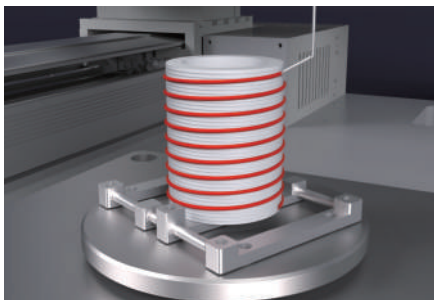

Rotational printing (vertical)

A printing method that ejects material onto the side of a rotating structure.

Housing options

- We have three housing options : general type, GMP-exclusive type, and constant temperature and humidity type.



Normal type

Minimize the influence of the external environment by separating the printing zone from the outside.



Constant temperature and humidity type

Keeps the internal temperature and humidity constant using the internal constant temperature and humidity device.

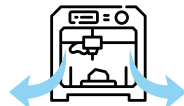

GMP-exclusive type

Maintains an environment suitable for cell printing using HEPA filter and UV.

Other specifications

- We provide an optimal printing environment by introducing components that can be operated even within a GMP environment. All multi-heads print in the exact position on all axes (X, Y, Z) with the automatic nozzle compensation device.

GMP-specific parts



Pneumatic hoses (Class 1)



Filters (dust & moisture free)

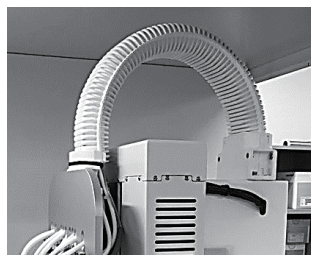

Cable bearings (low-dust)

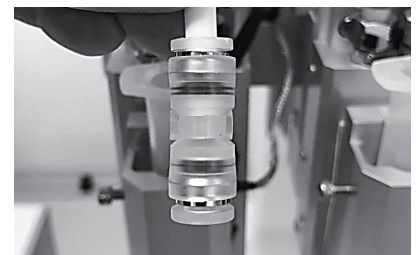

Pneumatic fittings (cleanroom only)

Automatic multi-heads nozzle compensation device

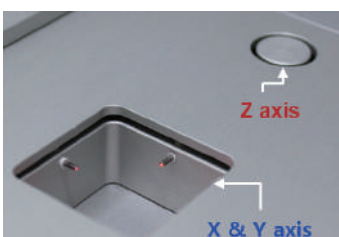

Nozzle compensation sensor

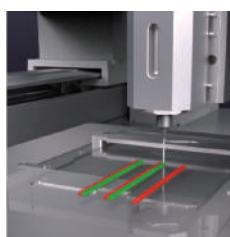

Application results

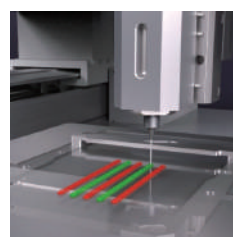

Basic specifications for 3DX printer

Driving Part	Transport resolution	±1 μm (for X, Y, Z stage)
	Repeatability	±10 μm (for X, Y, Z stage)
	Feed speed	1~1,500mm/min (for X, Y, Z stage)
	MPG specification	Adjustable in 1, 10, 100μm increments
	Drive unit specifications	3-axis orthogonal configuration (gantry or stack)
	Additional specifications	Flat or vertical, horizontal rotating stage
	Drive method	Precision servo motor & driver application
Printing Part	Printing method	Precision pneumatic discharge method
	Printing operating area	Within 200×200×150 mm (specifications can be changed)
	Head configuration	For polymers and hydrogels only
	Head temperature control function	Polymer only: RT to 200 °C Hydrogel only: 4 °C to 60 °C
	Head dispenser specifications	Digitally controlled, 20~700 kPa
	Syringe capacity	Polymer head: 10, 30 ml (Stainless) Hydrogel head: 3, 10 ml (Plastic)
	Software	Drive S/W: CNC-based printing-only program CAD/CAM S/W: G-code generation and modification program based on 3D CAD data
Equipment specifications	Size and weight	(General type) 800×800×1800mm, 300kg (GMP) 2300×1100×1950mm, 500kg
	Operating voltage	220V 60Hz
	Power consumption	1.5kW or less

Proven 3D Bioprinting Platform for Clinical Applications

3DX Printer has been creating medical devices for clinical applications for over 10 years. Supplies medical devices for global medical device companies. (BBraun Korea, Johnson&Johnson Medical Korea)

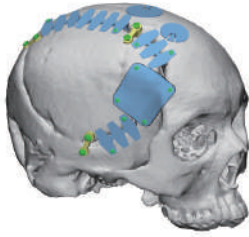

Cranio Facial Implants (CFI)
 Contract with B.Braun Korea
 Launched in April 2021. Used in 67 hospitals (as of 2022.06).
 FDA approval submitted (expected 2025)



Patient Specific Implants (PSI)
 Contract with Johnson and Johnson Medical Korea in March 2023.
 Expanding in Asia - Oceania



KC Certification
(Korean Certified Printer)



GMP Compliance Certificate
for high class medical device



Patent Technology Award



2021년 특허기술상
 총무공상 특허등록 제10-2083788호

34 Korean registered patents related to 3D printers / **35** Overseas registered patents related to 3D printers / **13** Utility models and trademarks



Clinical Cases using 3DX Printer

World's first successful transplantation of a 3D bioprinted organ (trachea).
Patient-specific 3D bioprinted trachea with allogeneic cells for a cancer patient.

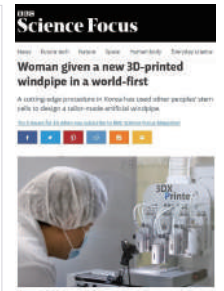
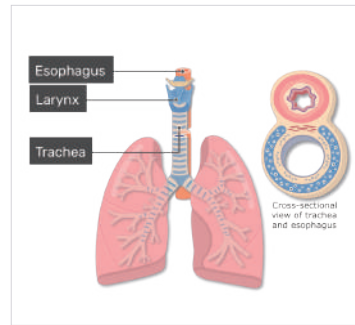
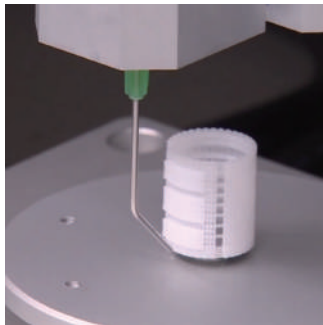

BBC: Science Focus(2024)

Clinical success of 3D-printed artificial ear for microtia patients.
3D bioprinted biodegradable scaffold implant for customized ear reconstruction.



3D image before surgery



3D modeling



Printed artificial ear



3D image after surgery



Successful implantation of artificial support using 3D printing in patients with skull collapse.
Customized artificial support implant for Ukrainian patient with war-induced skull collapse.

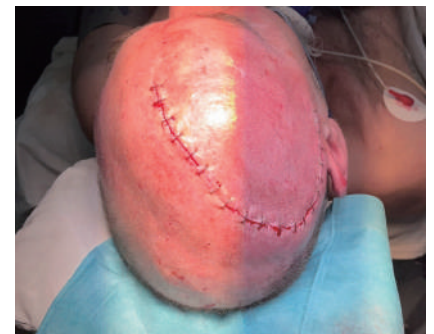
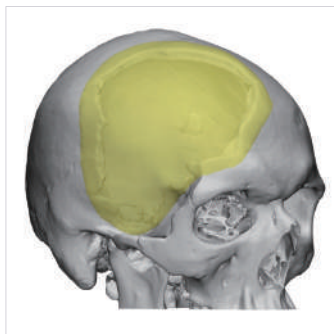

Patient-specific 3D printed artificial scaffolds. Korea's first 3D-printed biodegradable facial bone implant.

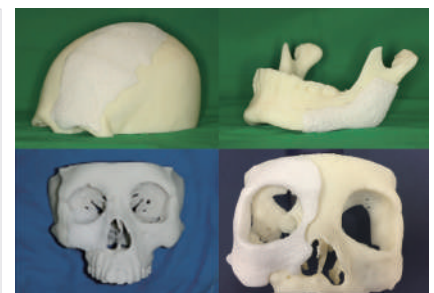
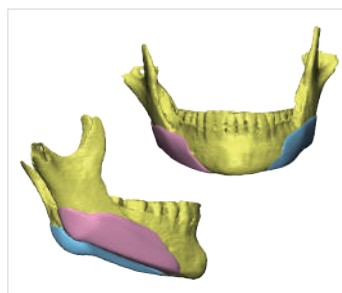
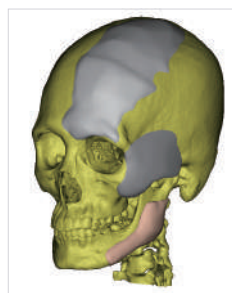
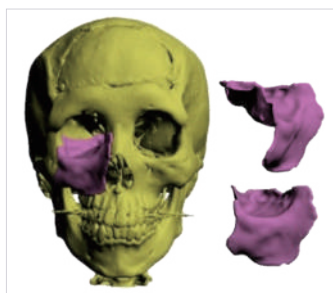

Sales and joint research institute



Commercial Medical Devices Produced by 3DXPrinter

"TnR PSI"

Patient-specific reconstruction of craniofacial defects



"TnR CFI"

Repair of craniofacial lesions and trauma

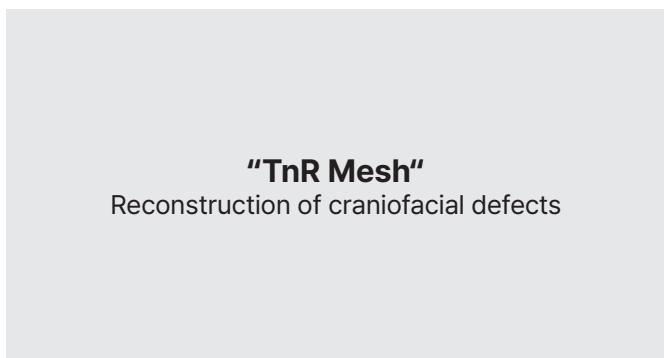

"TnR Mesh"

Reconstruction of craniofacial defects



"TnR Nasal Mesh"

Support of the septum during septal correction surgery

T&R Biofab manufactures medical devices with a porous structure made of composite materials such as PCL (Polycaprolactone) and B-TCP (Tricalcium phosphate) using a 3DX printer.

The porous structure implemented with the 3DX printer helps various cells of surrounding tissues to move inside the support and produce extracellular matrix such as collagen to reconstruct the tissue. Afterwards, the inserted artificial support is safely decomposed by hydrolysis in the body and is ultimately replaced with autologous tissue.

The world's largest 3D printing medical device product approval

- Obtained Class 4 medical device product approval for 13 items (over 13,000 models)
- The most clinical cases in the world (over 60,000 cases as of June 2022)
- Publication of clinical papers (16 SCI level papers)

In-house infrastructure for development, licensing, production, and clinical follow-up for 3D bioprinted medical devices

"With the completion of platform technology, various products are being developed and released to the market"

Scientific Publications using 3DX Printer

"Liver spheroid"

Advanced Materials (2021) DOI : 10.1002/adma.202102624

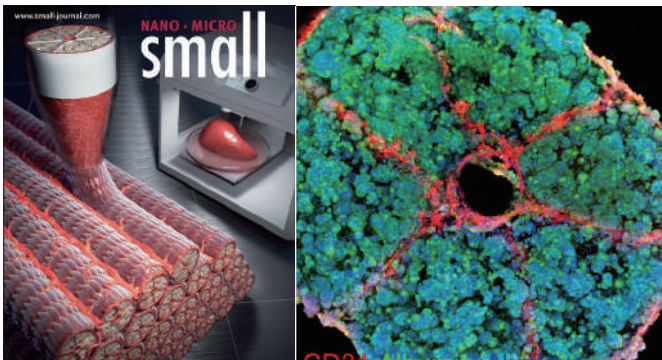
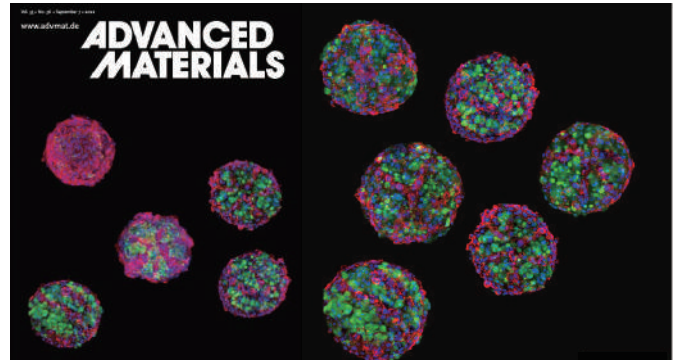

"Liver lobule structure"

Biofabrication (2018) DOI : 10.1088/1758-5090/aac70b
Small (2020) DOI : 10.1002/smll.201905505

"Artificial blood vessel"

International Journal of Bioprinting (2023) DOI : 10.18063/ijb.726

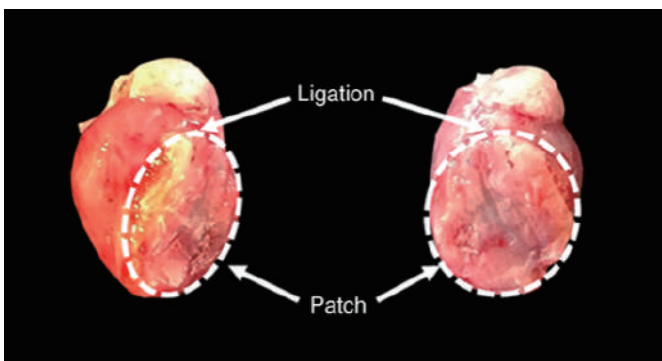
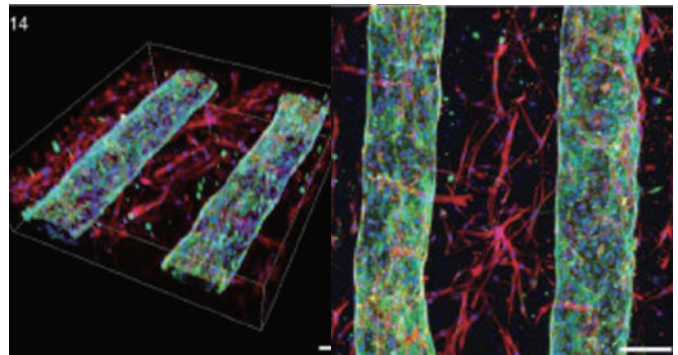



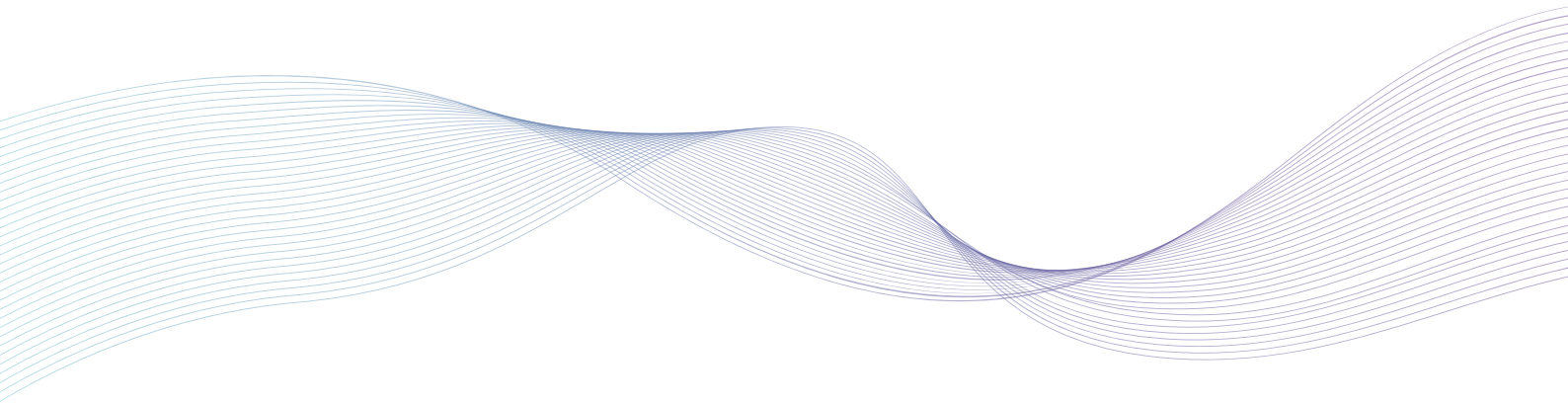

"hMSC-Patch"

Nature Communications (2019) DOI : 10.1038/s41467-019-11091-2

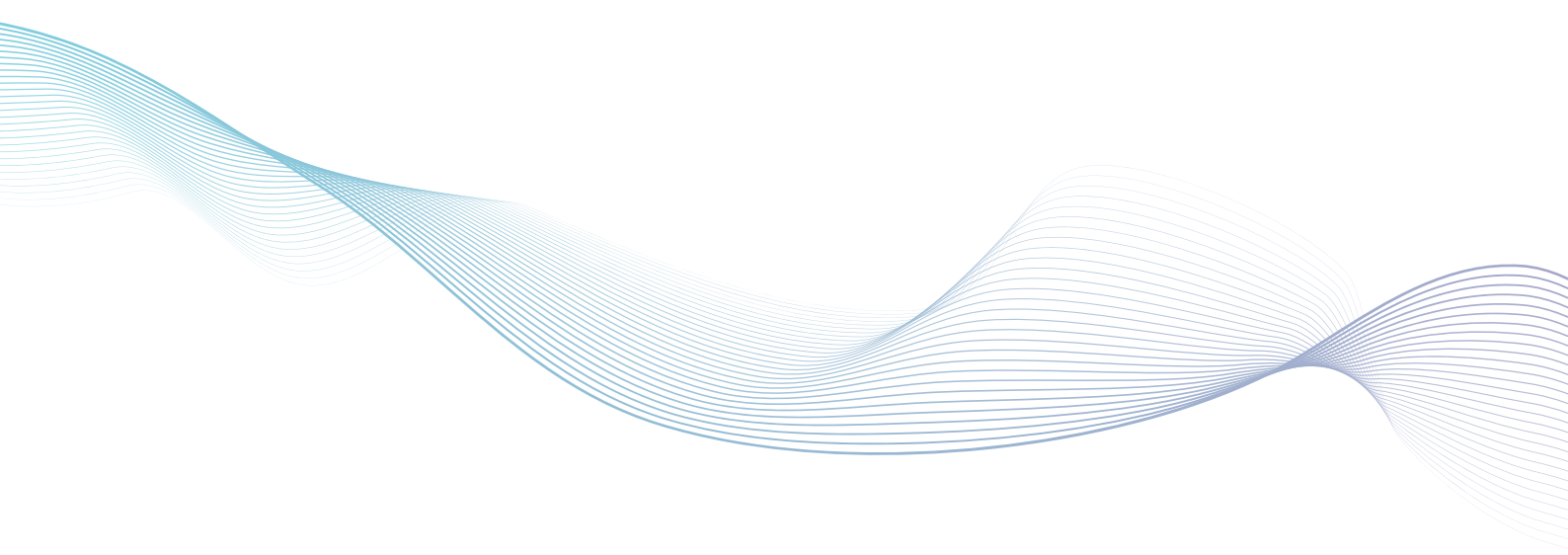
3DX printer is a 3D bio-printing platform that guarantees optimal performance tailored to the user's environment and need through technical support from professional researchers. As a testament to this, research enabled by 3DX printers are consistently published in leading international academic journals. 3DX printer is being used in top research institutions, including Georgia Institute of Technology in the United States, Pohang University of Science and Technology, Seoul National University, and Seoul National Hospital.





 www.linkedin.com/company/tnrbiofab
 www.facebook.com/tnrbiofab
 www.youtube.com/@trbiofab4420

Headquarter 96, Mayu-ro, Siheung-si, Gyeonggi-do, Republic of Korea
R&D Center 242, Pangyo-ro, Bundang-gu, Seongnam-si, Gyeonggi-do, Republic of Korea
Seoul Office 107, Dosan-daero, Gangnam-gu, Seoul, Republic of Korea
info@tnrbiofab.com **www.tnrbiofab.com**